

Technical Data Sheet

WEISS™

FV05CP

150mm Inline Fan Unit

Boxed

Dimensions

Fan Size

150mm

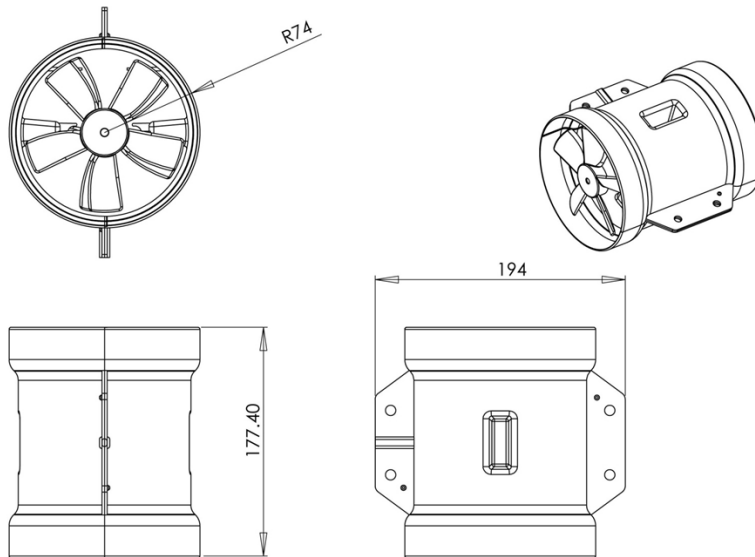

Specifications

N/A

Approval

N/A

Features

- Easy to install
- 3 year warranty
- Hi-static pressure

Technical Data Sheet

Product Use

The FV05CP is an inline fan unit that can be used for the extraction of mist and steam.

Typical applications:

- Bathrooms
- Toilets
- Laundries

Environmental Conditions

Climatic conditions	class 3K5
Temperature	0...+50°C
Humidity	<95% r.h.

Standards

Test standards	A/S NZS 3350.2.80:1998 Amdts 1-3 "Electric Fans"
Test Report No	SD3190
EMC Compliance	This is a Level One product with a C frame motor that has a very low risk of causing EMC Interference

General

Weight	0.9kg
Colour of front fascia	N/A
Housing Material	Flame Retardant ABS

Ordering

When ordering please give name and type,	
Reference	FV05CP
Barcode	942000490052-5

Technical Data

Power Supply	230 VAC
Power Consumption	max. 0.4 amp
Supply Line Fusing	max. 10A
For Solid Wires	2 x 1.5mm ²
Motor	230-240VAC 50Hz 0.4Amp
Motor Insulation Class	B1
Motor Protection	Thermally Protected
Total Product Wattage	40 Watts
Free Air Fan Performance	362m ³ /hr 100.6L/sec
Installed DB rating at 1.5m	45Db